

Quantifying the Safety Level in the Danish Building Fire Regulations

Fredrik Nystedt
Øresund Safety Advisers AB
P.O. Box 82
SE-201 20 Malmö
SWEDEN
fredrik@oresundsafety.se

Tomas Rantatalo
Fire Safety Nordic AB
Orkestergatan 55
SE-371 49 Karlskrona
SWEDEN
tomas.rantatalo@firesafety.nu

Charlotte Micheelsen
By- og Boligministeriet
Slotholmsgade 1
DK-1216 København
DENMARK
chm@bm.dk

ABSTRACT

The paper presents results from a Danish study where the safety level in case of fire for a number of buildings have been examined. The analyses were made with the aim of trying to establish acceptance criteria to be used in risk-informed building design. An event tree based quantitative risk analysis method was used. It was not possible to give recommendations for national acceptance criteria. The main reason for this conclusion is that the reliability and the risk analysis methodology could be questioned. Without standardized input data and calibrated calculation methods it is most likely that the assessed safety level will be varying with great magnitude between different engineers. A comparison with acceptance criteria would there be unfair. Risk analysis is however recommended to be used as a decision tool when designing fire safety in high-risk buildings and in buildings where the traditional code compliant solutions are not applicable.

INTRODUCING PERFORMANCE-BASED CODES IN DENMARK

In 1998, Denmark initiated a transition towards performance based building regulations in the field of fire safety. One of the main prerequisites for the work was that the transition should not result in a lowered safety level than what is accepted today. No matter if a prescriptive solution is adopted or analytical methods are used, the society demands that the achieved safety level should be the same. It was suggested that risk analysis should be used to identify the safety level. Risk analysis should also be used by engineers to show that the building complies with the acceptable safety level. Essential questions that arise early in the work are outlined below.

- Is there enough knowledge and experience with risk analysis in the field of building fire safety engineering?
- Are the suggested methods transparent enough to be used by different engineers and give satisfactory comparable results?
- Which is an acceptable level of safety and is available input data satisfactory?

Parallel projects have been managed on the development of the code, engineering guidelines and the quantification of the safety level between 1999-2001. A draft of a new building code with societal and functional objectives together with performance requirements have been produced. Two guidelines on code complying solutions were developed. The first guideline consists of a revision of the old prescriptive code with a presentation of deemed to satisfy solutions. The second guideline involves acceptable engineering tools for design as well as acceptance criteria to be used in evaluation. A hypothesis was formed stating that it should be possible to identify the safety level provided by today's regulations. This safety level could be quantified by the use of event tree based fire risk analysis (Olsson, 1999). A number of

buildings, all considered to have an acceptable safety level, were selected for the forthcoming risk analysis. These buildings are a hotel with a restaurant, two types of elderly homes, a school and an office building.

METHODOLOGY FOR FIRE RISK ANALYSIS

A risk-based fire safety engineering method performs the quantification of the safety level. The method uses event tree technique and combines calculations of fire development with escape modeling for each scenario. The method has been developed by Lund University and is documented in Frantzich (1998), Jönsson & Lundin (1998) and Olsson (1999). The complete fire safety design process consists of the following five steps; qualitative design review, quantitative risk analysis, risk evaluation, sensitivity analysis and optimization. The qualitative design review is used to highlight input related to fire safety in a systematic manner. The review collects all the necessary information for the forthcoming risk analysis. The risk is evaluated and the effectiveness of different fire safety strategies is assessed. A sensitivity analysis is performed to identify strong and weak aspects of the chosen fire safety design. Eventually there is a possibility to perform an optimization where the adopted fire safety design is configured with the use of trade-offs to meet the acceptance criteria for the specific building. The process is illustrated in Figure 1.

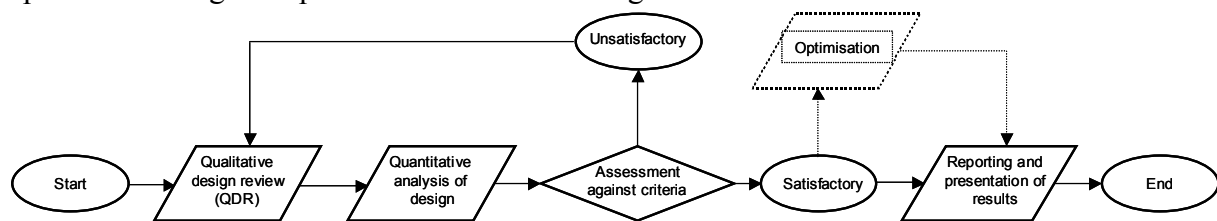

Figure 1 The basic fire safety design process

Fire is a transient process that affects a building and its occupants in different ways at different stages. The process of fire safety design is complicated by the fact that time is one of the key design parameters. When assessing the number of people exposed to untenable conditions a comparison between two time lines is made. One of these time lines represents the course of the fire, in terms of its size, rate of burning and smoke or toxic gas concentration. The other time line represents the response to the fire by the occupants. These time lines and the specific expressions used are presented in Figure 2. Note that the expressions differ between countries.

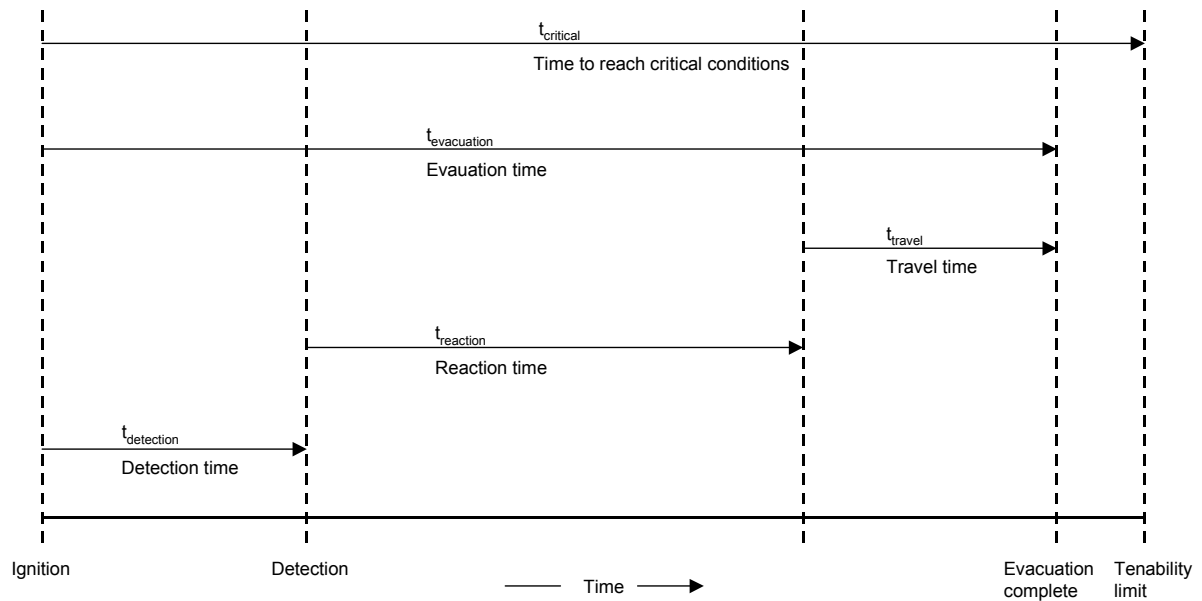

Figure 2 Example of a time line comparison of fire development and evacuation

The risk analysis itself is carried out by quantitatively evaluating a number of fire scenarios. The evaluation calculates the fire development and the evacuation process for all scenarios in the event tree. Event trees are logic diagrams, which can be used to illustrate the sequence of events involved in ignition, fire development and control, as well as the course of escape. Figure 3 shows an example of a simple event tree for a fire. The risk for each scenario is calculated by multiplying the probability of the specific scenario by its consequence. The total risk associated with a building is the sum of the risks for all scenarios in the event tree. Possible outcomes of such an event tree analysis are individual risk, average risk, degree of risk aversion and maximum consequence. The purpose with an event tree is to consider both successful and unsuccessful operation of the fire safety measures in the building.

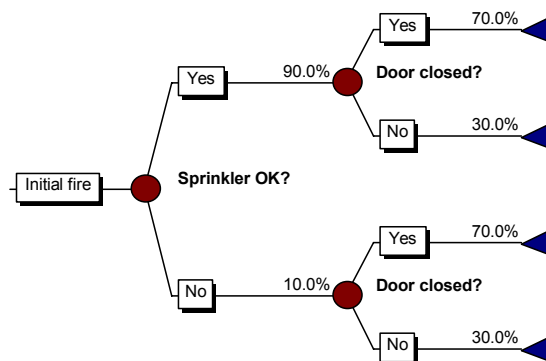

Figure 3 Example of part of a simple event tree.

To produce a definitive measure of the risk to life it would be necessary to consider every combination of fire source, fire scenario and target location within the building. However, the computational effort required increases with the number of sources, scenarios and targets considered. The fire development depends on fire growth, ceiling height, rate of heat release, ventilation, etc. Hazardous conditions are loss of visibility, exposure to toxic products and exposure to heat. The hazardous conditions are defined in the building regulations. The evacuation process is depending on detection, reaction and travel times.

THE DANISH SAFETY LEVEL

When a building is designed in complete accordance with the Danish building fire regulations it is considered to have an acceptable level of safety. This is the fundamental basis for the work on identifying a national safety level. The quantitative risk analysis makes it possible to evaluate some important risk measures. These are the individual risk and the societal risk. The individual risk measures consider the risk to an individual who may be at any point in the effect zones of incidents. The societal risk measures consider the risk to population that are in the effect zones of incidents. In this project the effect zone is the analyzed buildings. The individual risk is the probability that one or more people would be exposed to untenable conditions in case of fire. The societal risk could be expressed by an FN-curve or in this case the similar risk profile. The risk profiles for all the analyzed buildings are shown in Figure 4.

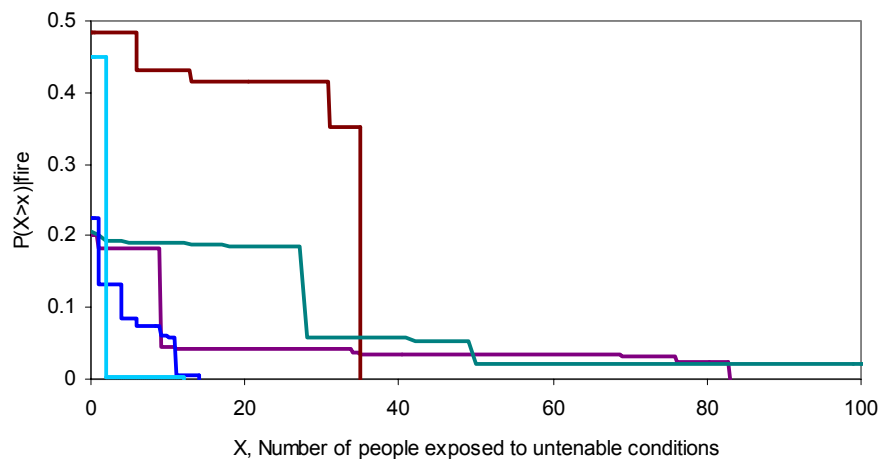

Figure 4 Risk profiles for all analyzed buildings.

Which risk profile that belongs to a certain building is less important. More important is the variance between the safety levels that could be seen in Figure 4. As a complement to the analysis of the safety level achieved by the regulations some further analysis were performed in order to investigate the effect of various fire safety measures like sprinkler system, fire alarm, changes in fire compartment sizes, etc. Table 1 outlines a summary of the risk measures for each building.

Table 1 Summary of the risk measures for each building

Building	Fire safety measure	Individual risk	Average risk	Maximum consequence
Elderly home 14 occupants	Br 95	0,23	1,2	14
	No smoke alarm	0,34	2,0	14
	Sprinkler system	0,08	0,5	14
Elderly home (dormitory) 82 occupants	Br95	0,45	0,9	12
	No sprinkler system	0,45	1,4	12
Hotel with restaurant 647 occupants	Br95	0,2	9,1	236
	Smoke and escape alarm	0,17	5,8	128
	Sprinkler system	0,16	5,6	236
School 365 occupants	Br95	0,20	4,3	83
	Manual escape alarm	0,18	2,8	83
	Smoke and escape alarm	0,07	1,5	83
	Sprinkler system	0,02	0,8	83
Office building 160 occupants	Br95	0,48	14,8	35
	Manual escape alarm	0,44	13,8	35
	Smoke and escape alarm	0,43	10,7	35
	Sprinkler system	0,15	3,5	35

The differences in safety level between the buildings are obvious. Considering the individual risk measure the office building and the elderly home (dormitory style) has the highest risk. The risk level in the school, elderly home and the hotel is approximately half as low.

INTRODUCING ACCEPTANCE CRITERIA

Acceptable Risk and Risk Perception

The discussion on acceptable levels of risk is commonly focused on two objectives. The first objective has the individual as its basis and weights the risk of an activity versus the personal advantages. The second objective is based on a societal point of view and studies the risk versus its advantage for the society as a whole. A number of countries have decided upon acceptance criteria for different activities and establishments. Wolski et al (2000) discusses how risk perception could be included in building fire regulations. The perception of risk depends on a number of risk factors as seriousness, controllability, necessity, exposure pattern and degree of volition. By introducing risk conversion factors to the presented risk factors it is possible to link how the risk is experienced between different building types and activities. Statistics provide information on the risk level in e.g. residential buildings. The risk conversion factors could then be used to derive which level of risk that should be considered suitable for e.g. a high rise office building. It is proposed that acceptance criteria for fire in buildings should vary depending on the type of building. This is the only way to reflect the differences in risk perception. A number of design guides and building codes classifies the buildings into different classes in order to reflect risk perception. Such a classification should be based on both the building and the activity. One example is found in NKB (1994).

The Reliability of the Risk Analysis Methodology

Sensitivity analysis shows the risk analysis methodology lacks of reliability. One engineer could get quite a different result compared to another engineer. This unreliability is due to the complex gathering of input data that is directly linked to the results. The sensitivity analysis has been carried out by the use of the extended QRA methodology presented by Frantzych (1998). The extended QRA allows the use of input data as probability distributions instead of point estimates. The result is shown in Figure 5.

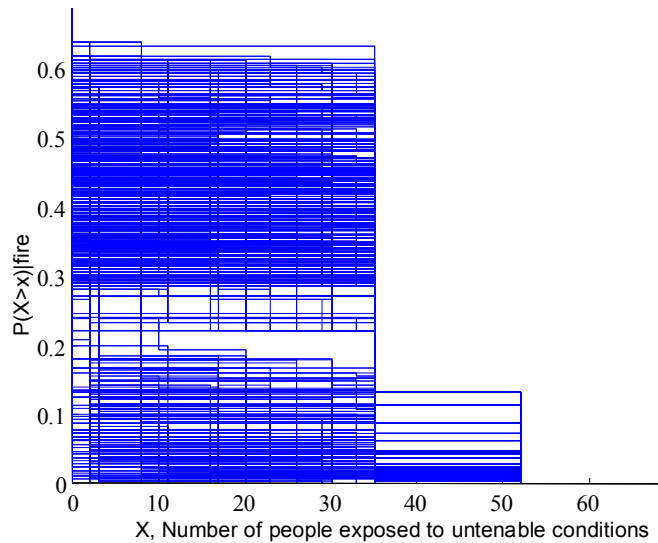

Figure 5 Sensitivity analyses for one of the buildings.

If one thousand engineers would have carried out a risk analysis for exactly the same building it would have been possible to achieve one thousand different answers, which are illustrated by the risk profiles in Figure 5. Since Frantzich (1998) developed the methodology a number of analysis has been carried out on different buildings. However, a benchmark study has not taken place yet where engineers have analyzed the same building with the same methodology. The reliability of the methodology is therefore not completely known. The methodology is probably in need for some kind of calibration or standardization of input data. A calibration aims at dealing with the most important uncertainty factors. One way to perform a calibration is to decided upon design values by analyzing statistics, introducing a risk based acceptance criteria and define and document the fire risk analysis process.

Comparison with Statistics

It is quite hard to make comparisons between the results from the risk analysis and the results from statistical analysis of incident data. In the statistical material it is possible to find the probability of getting wounded or killed in the event of fire. If a comparison should be applicable towards statistics, the risk analysis must have been carried out with reality-based prerequisites. It is also important to differ if the risk analysis aims at analyzing an existing level of safety or aims at designing a building. When used in design it is important that the safety is assured for most of the fires that could occur in the building. Input data for fire growth, people density, etcetera should therefore be chosen reasonable conservative.

The risk analyses in the project have used reasonable conservative input values. The comparison with real-life statistics is therefore difficult. One example is the chosen people density in assembly buildings. The building regulations state 0.5 people/m² as a design value. Live investigations shows far less people densities than that. An average of 0.1 people/m² has been found in Angerd (1999). An additional reason for differences between statistics and the results from the risk analyses is the use of too conservative values for untenable conditions. There is no clear link between design values for untenable conditions in the building regulations and when people actually get wounded or dies. It is also hard to estimate a specific fire frequency for a single building.

ESTABLISHING ACCEPTANCE CRITERIA

Acceptance criteria for fire in buildings should be based upon how often a certain consequence is allowed to happen in a building. Such acceptance criteria could be established by the use of an engineering approach (Olsson, 1999) or by analyzing statistics. The engineering approach has its basis in risk analysis for representative buildings that are design in complete accordance with existing codes. The result from such analyses could be considered as an acceptable level of risk.

It has not been possible to establish a uniform fire risk acceptance criterion for all buildings. Following the arguments above on risk perceptions this should however not be the case. Acceptance criteria should refer to the different safety classes and service categories difficulties in comparing the results from the risk analysis with real statistics. There has to be more work done before we can use the some established acceptance criteria for design. Some of the most important things to work with are to evaluate the effects of using lethal instead of untenable conditions when evaluating the buildings performance. There is a gap of knowledge and experience on design fires and fire scenarios. The methodology for the quantitative risk analysis must also be calibrated so that it better reflects real life situations. Until further research and development has been undertaken the assessment against criteria must be performed by comparative means and the results should be used as an aid for decisions making.

WHY USE THE PROPOSED METHOD?

Before we started the process we decided upon which method that should be used. Risk analysis in the field of fire safety is not that widely used and therefore we had not that many methods to choose from. A quantitative method was needed. Questions that had to be answered if the method could fulfill what we needed was the following (Britter 1993):

- Does the method predict the right problems and gives correct answers?
- Are inputs to the method easy to get?
- Are the uncertainties and limitations well known?

Does the Method Predict the Right Problems and Gives Correct Answers?

To the first question it is clear that the method predicts the safety of occupants in the building in case of fire. There are however difficulties in deciding whether the answers given are correct. There are uncertainties related to the untenable conditions used as design criteria for evacuation. The results from the “model” and real situations are not comparable, which has been identified by several analyses. There are needs for adjustments in the model. But, when the main focuses are on the valuable information that is achieved, the exact values are of minor importance.

Are Inputs to the Method Easy to Get?

The engineer needs to be very careful when comparing the results from the risk analysis with statistical data. Most important is if the two approaches measure the same variables and are collected in the same way. As design criteria the untenable conditions in NKB (1997) code were used. Difficulties came up when the results achieved by using the defined untenable conditions criteria were compared with the statistical definitions of minor injuries, major injuries and killed.

The use of risk analysis requires a quantification of the risk. The risk can be quantified in terms of the expected number people injured or killed in fire per year. Other measures could also be used, but these are the most common in other fields of application areas and it is suggested that these measures should be used for fire safety in buildings. A lot of future work is related to the statistical input data. Such data is often difficult to get and very frequently there is a huge need for data validation. The international fire safety community has an important role in trying to collect and distribute relevant fire statistics. Fires with extensive and serious outcome are quite rare on a national basis and by using data from around the world the reliability of various predictions would increase. The event tree requires data on the reliability of active and passive fire safety systems. Such data involves the reliability of sprinkler systems, closing devices for doors, fire alarm systems and public notification systems. Valid and robust input data for the reliability of active and passive fire protection systems are important. Most of these data are from the 1960–1980 and sometimes very difficult to apply in a modern building. For the purpose of the analyses in this project it is assessed that there is enough input data, but it would have been a great advantage in the future if data collection could be done similarly world wide.

The design fire is a central part of the analysis. Therefore it must be carefully selected. In this project a combination of recommended α^2 -fires and uniquely designed fires have been used. When only considering the risk to life it is the early stage of the fire that is most important. Several fire tests show that a fire do not start its continuously growth before it has reached a certain size. This time from fire start to the point where there is a continuous development is called the pre-burning time. This time period is very seldom mentioned in literature. A pre-burning time can vary from seconds to several hours depending on which materials that are involved in the fire. One approach to estimate pre-burning times is to study the results of fire tests (Baubrauskas, 1995). Examples of pre-burning times are nil seconds for flammable liquids and 2 – 3 minutes for electric fires in porous materials. During the pre-burning time it is assessed that the people close to the fire detects it and begins the evacuation process. The information on where the fire is initiated and if there is a successful early extinguishment cannot be found in statistical data. This information is crucial to the outcome of the fire, but due to the lack of reliable statistics this event is excluded from the analysis. In building codes there is a principal requirement that buildings should be designed so that the escape or rescue of people can be assured in the event of fire. It is not suitable to design the fire safety measures of a building based on the fact that the likelihood of fire is extremely low. When performing the fire risk analyses in this project statistical data from all fires have been used. It can be discussed if events that never could be of any danger should be taken out from the statistical material. The reason for using information of all possible fires is to be able to compare the fire risk with other risks in the society.

One of the more difficult areas in the analysis is when human behavior in fires should be taken into account. Available knowledge on design times to initiate an evacuation and walking speed has been adopted from various handbooks. This problem is not specific for fire risk analyses. It is related to almost every fire safety engineering application. It would have be suitable to use the real-life experience from fires around the world, but for doing so the community needs to standardize the collection of data and make it available for all fire safety engineers. The event tree approach of this risk analysis methodology is in it self a sort of sensitivity analysis. For each scenario it is possible to consider the successful or non-successful operation of various safety measures. A varying fire growth could be analyzed together with possible outcomes when moving out of the building. In this way have a more realistic result from the analysis.

Are the Uncertainties and Limitations Well Known?

The models limitations seem to be well known. The two separate models – fire development and evacuation – are frequently reviewed and have been through extensive validation processes. The event tree technique is a common method in reliability engineering for predicting the probability for different chains of events. In this case these events are different fire safety measures and their effects on the fire safety level. For an experienced and competent engineer in the field of statistical analysis and fire safety engineering it is believed that the limitations are well known.

PROMOTING FIRE RISK ANALYSIS

The situation is considered satisfactory enough to recommend the use of risk analysis when using analytical methods for the design of certain buildings. It has not been possible to establish a uniform fire risk acceptance criterion for all buildings. Neither was it possible to present a national safety level that could be used for all types of buildings. But it is very important to have risk analysis as one of the evaluation and verification methods to be used as a basis for the decision of appropriate fire safety measures for a building. When non-code compliant solutions are used risk analysis is a useful tool to verify if the building has an acceptable safety level. Comparative analysis could be performed where the deemed to satisfy solutions provide an acceptable level of safety. The deemed to satisfy solutions in the building code has been accepted by the Danish community and will continue to set the standard of the fire safety in buildings. Even if there is a safety level set by the community the risk analysis provides a lot of important information.

The use of a risk analysis method will result in very well documented review of the buildings different safety measures and their importance. It is possible to identify if and how the measures are related to each other. The review collects all the necessary information for the forth-coming use of the building. The result of the risk analysis can also identify the weak links in the fire safety strategy that could cause problems during the lifetime of the building. During construction the results could be used as a basis for building control. Some installations in the building, e.g. automatic closing of doors, can be shown in the analysis to be of great importance for the safe evacuation of a building. Therefore one should put more efforts to ensure their function in comparison to other safety measures that would have a minor role for the fire safety in the building.

By using an alternative evacuation or fire safety strategy it is possible to achieve a more robust solution. The result gives guidance for the choice of strategy. Effects of a failure of the sprinkler system could perhaps give consequences that cannot be accepted. Even though the probability is low we have to be sure that the consequences is tolerable. The project team together with the local government must sometimes set the acceptable risk level. The discussion before deciding upon which safety level that is acceptable results in very useful input to the decision if a building is safe enough.

The limitation of using the detailed regulations for complex buildings with a lot of occupants has been discussed for a long time in Denmark. By using a risk analysis we can present the results with different risk measures and get more information about where it is possible to use the traditional deemed to satisfy solutions. The risk analysis must be fully documented so it can be used in a constructive way and not only give guidance for a certain object. In this project the Danish ministry of housing and urban affairs will get important input that can be used in the work towards a national safety level. The risk communication among regulators

and others have been initiated and the way it is done by the Danish ministry is an important step.

CONCLUSIONS

The conclusions from the project are not only related to the derived safety levels. It is also related to the methodology. It is the first time that it is possible to perform an evaluation of the methodology in broader terms.

The new Danish building fire regulations proposes the use of both safety classes and service categories to decide which requirement on fire safety in buildings that should be applied. The higher class and category the building belongs to the more stringent requirements. The purpose of this approach is to consider peoples perception of risk and it is consistent with the work presented by NKB (1994). Wolski et al (2000) discusses how risk perceptions could be accommodated in the development of building fire regulations. Considering the nature of the risk in terms of volition, severity, familiarity, controllability, benefit, necessity, etc., the building regulations are formed so that they reflect peoples risk perception. Regulative requirement should e.g. be more stringent in a high-rise office building than a two-family dwelling.

It is considered that there is enough knowledge and experience with the use of risk-based engineering methods. The methodology is not a new invention. It just combines the advances in both risk analysis and in fire safety engineering to solve a design problem. It is purposed, based on the results from the analyses, that prescriptive rules cannot be used for complex buildings. These complex buildings with a high-risk level are for example hotels, shopping malls, assembly halls etc. The prescriptive rules do not always provide satisfactory solutions.

With the use of risk analysis a detailed review of the building capacity in case of fire is presented. Weaknesses are identified and there are fewer possibilities for misunderstanding the fire safety concept. The situation is considered satisfactory enough to recommend the use risk analysis when using engineering methods in certain buildings.

It has not been possible to establish a uniform fire risk acceptance criterion for all buildings. Following the arguments above on risk perceptions this should however not be the case. Acceptance criteria should refer to the different safety classes and service categories difficulties in comparing the results from the risk analysis with real statistics. There has to be more work done before we can use the some established acceptance criteria for design. The methodology for the quantitative risk analysis must also be calibrated so that it better reflect real life situations.

REFERENCES

Angerd, M., *Är utrymningsschablonerna vid brandteknisk dimensionering säkra?*, Rapport 5028, avdelningen för brandteknik, Lunds universitet, 1999 (In Swedish).

Danish Housing and Building Agency, *Building regulations BR95*, Copenhagen, Denmark, 1995.

Frantzych, H. *Uncertainty and Risk Analysis in Fire Safety Engineering*, Report 1016, Department of Fire Safety Engineering, Lund University, Lund, 1998.

Jönsson, R., Lundin, J., *The Swedish Case Study*, Proceedings from the 2nd International Conference on Performance-Based Codes and Fire Safety Design Methods, Society of Fire Protection Engineers, 1998.

NKB, *Performance Requirements for Fire Safety and Technical Guide for Verification by Calculation*. NKB Committee and Work Reports 1994:07 E, Nordic Committee on Building Regulations, 1994.

Olsson F., *Tolerable Fire Risk Criteria for Hospitals*, Report 3101, Department of Fire Safety Engineering, Lund University, 1999.

Wolski, A., Dembsey, N.A., Meacham, B.J., *Accommodating perceptions of risk in performance-based building fire safety code development*, Fire Safety Journal, 34 pp 297-309, Elsevier Science Ltd, 2000.